

DURA-STILTS®

ASSEMBLY AND INSTRUCTION MANUAL

PLEASE READ CAREFULLY
BEFORE
ASSEMBLY OR USE

Great care and extensive design and development work has been undertaken to provide for you this quality tool. Proper assembly, care, inspection and maintenance, combined with responsible use, is crucial to your product satisfaction and personal safety.



F MODEL
Fixed Length Legs

MODELS F14, F16, F18, F20, F22, F24



D MODEL
Variable Length Legs

MODELS D14-22, 018-30, D24-40

ATTENTION! READ THIS!

When using leg extension devices (stilts) you are elevated off the floor. If you fall, you could be seriously injured. It is absolutely imperative that you spend time learning to walk on, and becoming proficient with your Dura-Stilts before trying to perform work on them. It is your responsibility to read and observe these instructions including the do's and don'ts. It is also your responsibility to use stilts that are well maintained, to insist on a clean, clear work area, and to always exercise caution while using Dura-Stilts. Keep all bolts tight. Special attention should be given to the entire strut tube assemblies and wing bolts in this respect. Surveys have shown that there are fewer loss time accidents per million man hours worked on leg extension devices (stilts) than any other type of personal scaffolding. WE WANT TO KEEP IT THAT WAY. If you have any questions concerning this product please contact us before assembly or use.

We will not be responsible for any accident resulting from irresponsible use, improper use, or failure to inspect and maintain adequately.

BINDING ARBITRATION

USE OF THIS PRODUCT SIGNIFIES YOUR WILLINGNESS TO AGREE TO THE FOLLOWING BINDING ARBITRATION CONTRACT.

In consideration of the timely and cost effective resolution of controversies between the parties, all such controversies regarding the Agreement or the rights of parties hereto, shall be submitted to arbitration before the American Arbitration Association. The parties agree to waive their rights to a jury trial, punitive damages, tort damages, attorneys fees, cost, or expenses as a result of this Agreement or enforcement of the arbitration's award, the parties agree that venue lies in Oklahoma County, State of Oklahoma, and the parties waive their right to a jury trial for any claims or counter claims. This arbitration clause shall survive the termination or breach of the agreement. If any provision of the Arbitration Clause is held invalid, that invalidity shall not affect other provisions of this Arbitration Clause.

If you are unwilling to agree to and abide by this BINDING ARBITRATION AGREEMENT YOU MUST NOT USE THIS PRODUCT

LOAD LIMIT 225 LBS. DO NOT EXCEED

STEP A CHECK COMPONENTS

1

Dura III Adjustables

(2)

1 left and 1 right

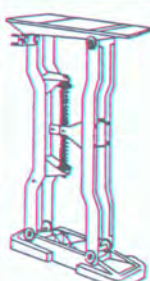
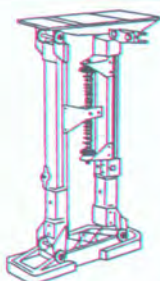

Fixed Heights

(2)

1 left and 1 right

2

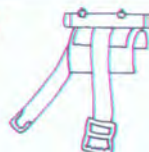

Upper strut tube assembly (2)

Lower strut tube (2)



3

Lower strut tube mounting fasteners

Fixed

Adjustables



1/4-20 X 5/8 hex machine bolt (2)



1/4-20 hex lock nut (2)



1/4-7/16 washer (2)



Located on rear legs as shown

4

Strap Adaptor Kit

Strap Adaptor Fasteners (package)



Arch strap (long) (2)



Toe strap (short) (2)



Heel bracket (2)



#8x 1/2 phillips fast thread screw (8)



#8 flat washer (8)



#10x 1/2 machine screw (4)



#10 hex machine nut (4)

Suggested Tools for Assembly

1 phillips screwdriver

2 7/16 wrenches

1 7/16 nut driver

If mounting shoes, (optional)
you will also need...

1 3/16 drill bit

1 hand drill

STEP B ASSEMBLY

1 Strut Tubes

Loosen tube clamps. Insert lower strut tubes up through the bottom of the tube clamps. Leave tube clamps loose for now. (Fig. 1)

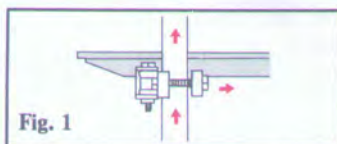

Fig. 1

2

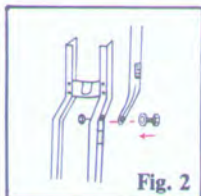

Fig. 2

Attach lower strut tubes to the brackets or holes provided (identified by labels) with the attached $\frac{1}{4} \times \frac{7}{8}$ hex machine bolts and washers position washers on top of strut tubes under bolt heads. **Tighten well** when assembly is complete. (Fig. 2)

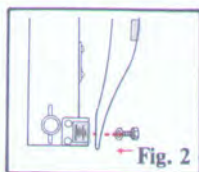

Fig. 2

3

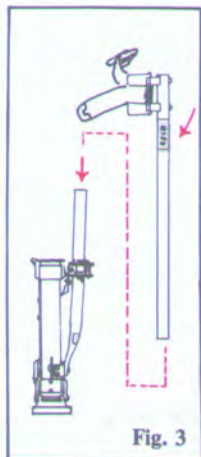

Fig. 3

Read the yellow label on the upper strut tube. Keeping the strap buckles toward the "toe" of the stilt legs, slide the upper strut tubes down over the lower strut tubes and through the tube clamps. Position so the leg straps are just above the large portion of the leg calves. **Note: Do not bend or "size" the leg bands.** (Fig. 3-4)

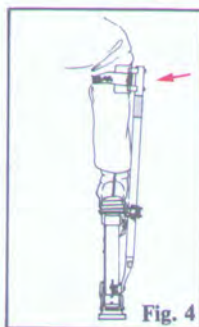

Fig. 4

4 How to properly tighten tube clamps **IMPORTANT!** Tube clamps are to be tightened just enough to prevent the leg band from rotating on the user's leg when stilts are used. Excessive clamping may imprint and seize the tubes together, tubes must be replaced. Stilts legs may also be damaged if tubes are hammered on or twisted harshly. Evenly tighten

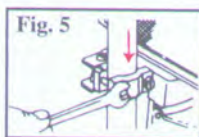

Fig. 5

the two tube clamp bolts until the tube clamp just starts to grip the upper strut tube, then tighten each bolt an additional $\frac{1}{4}$ turn. If strut tubes are secure. Stop! If additional clamping is needed, carefully tighten bolts $\frac{1}{8}$ turn at a time until strut tubes are secure. **STRUT TUBES DAMAGED BY OVERTIGHTENING ARE NOT RETURNABLE AS DEFECTIVE AND WILL NOT BE WARRANTIED!**

5 Position the tube clamps centrally in the clamp bracket slots, and tighten well. (Fig. 6)



Fig. 6

6 Shoe Mounting (Optional)

If you are mounting a pair of shoes to the Dura-Stilts, purchase an optional shoe mounting bolt package from your dealer. Place shoes in approximately the same position as shown. Your **outside** ankle bone should be directly over the rear pivot bolt.

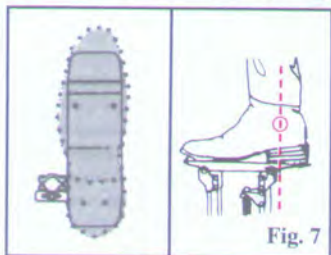

Fig. 7

From the underside of the foot plate, mark hole locations on the shoe soles. Remove shoes and drill $\frac{3}{16}$ " holes.

Using the No. 10 flathead screws and nuts provided in the optional package, mount shoes and tighten until the screws heads are flush with the shoe intersoles. Longer screws may be needed for mounting work boots with thicker soles. Note: soft shoes (tennis, etc) are not suitable for mounting. (Fig. 7)

Read the "Attention User" engraved in the top of the foot plate before proceeding.

7 Strap Adaptor Kit

Attach the heel brackets to the footplates using the No. 10x½ phillips machine screws and nuts. Adjust the heel bracket so your **outside** ankle bone is directly over the rear pivot bolt and **tighten well**. (Fig. 8)

Position the toe (short) and arch (long) straps on the footplates with the buckles on the same side as the strut tube. Secure the straps with the No. 8x½ phillips fast thread screws and washers. **Note:** The holes in the footplates are not pre-threaded so make certain the screws with washers are installed straight. (Fig. 9)

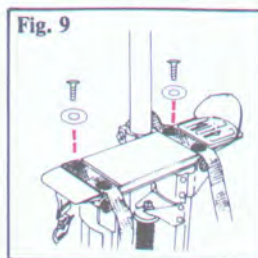

Footwear should have 90° heels of low to medium height. Do not use footwear with tall or acute angled heels. (Fig. 10)

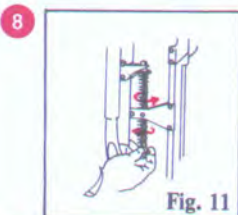

Set spring adjusters to minimum compression (Fig. 11)



Set adjustable Dura-Stilts to the lowest setting and tighten wing-bolts. (Fig. 12)

9 Take a moment now, and recheck all of the components you have assembled. Your Dura-Stilts should now be ready for trying on, and balance setting.

STEP C PERSONAL FITTING

1 Strap Tightening Sequence

Important—When mounting Dura-Stilts always buckle leg straps first before tying shoes, or buckling foot straps. When dismounting Dura-Stilts always unbuckle leg straps last, or after untying shoes or unbuckling foot straps. (Fig. 13)

2 Mounting Your Dura-Stilts

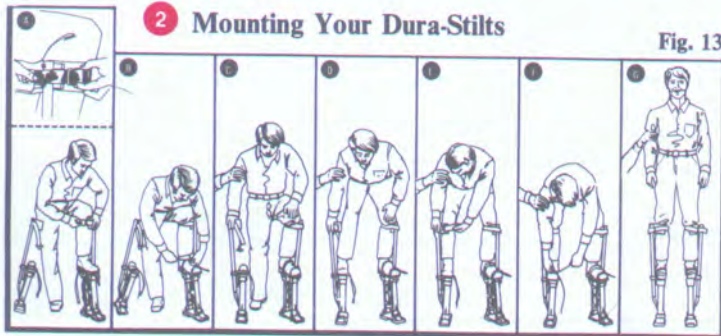
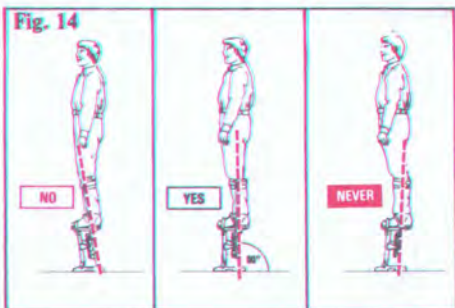

Fig. 13

Select a clear and level area away from doors, floor vents, stairwells, windows, etc. With the help of a colleague, strap on your stilts as noted above, and illustrated. Stand with your legs comfortably apart, collect your balance...and relax. (Fig. 13)

3 Forward/Rearward Balance



When standing erect Dura-Stilts should be in a neutral and vertical position (Fig. 14). If they have a tendency to lean forward or backward, do not attempt to correct by adjusting the action springs. First, check your alignment over the Dura-Stilts as in (Fig. 8-Foot). Then make the following adjustments with the help of a colleague or after removing your Dura-Stilts. If stilts lean rearward, loosen the tube clamps and rotate the legbands and strut tubes toward the rear, and **tighten clamps**. If the stilts lean forward rotate toward the front, and **tighten clamps**.

This adjustment is to insure proper forward and backward balance. If this adjustment requires that the legbands be rotated to where it is uncomfortable, the mounted shoes should be relocated, or the heel brackets be adjusted in the same direction as the needed rotation. **Note: Do not bend or "size" legbands.** (Fig. 15)

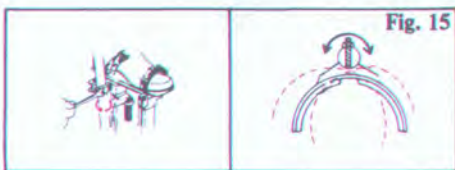

4 Lateral Balance

When standing erect, the legbands and upper strut tubes should apply a slight force against the side of your legs. If they pull outward or press excessively inward (see **important note below**) make the following adjustments with the help of a colleague, or after you have removed your stilts. (Fig. 16)

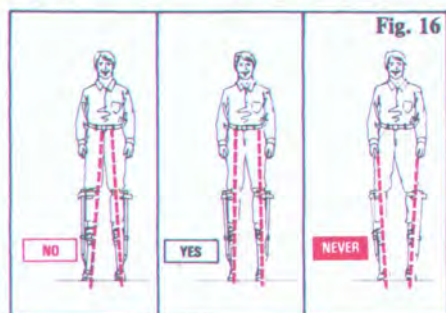

Loosen the bolts and nuts in the slotted brackets retaining the tube clamps. Slide the strut tube assembly and clamps in the direction necessary to apply slight inward pressure to your legs. **Securely tighten.**

A trial and error approach may be necessary to obtain this balance setting. (Fig. 17)

Tip: some individuals may find that sliding the assemblies inward may correct excessive inward pressure and sliding them outward may correct excessive outward pull.



IMPORTANT NOTE! READ THIS! When the stilts are properly adjusted, balanced, and used, the force exerted by the upper strut tubes and legbands on the wearers leg should vary in a range from 1 lb. to 15 lbs. If you are ever applying more than 25 lbs. force in any direction at any time to the upper strut tubes, you are using the stilts in an improper manner. They should therefore, be re-adjusted for lateral balance. If after having re-adjusted the stilts for lateral balance you still exert forces on the upper strut tubes in excess of 25 lbs., you must change your walking habits as the stilts are being improperly used. (If you are unable to estimate the amount of force applied to your leg by the upper leg band and strut, you can determine what 25 lbs. of force feels like against your leg by letting someone push against your leg with a bathroom scale and observing the pounds of force obtained. Also, a 25 lb. force to the upper strut tube #5 of a rigidly held Dura-Stilt will cause a deflection of 3/8" or less of the tube as measured at the end of the upper leg strut tube.)

IMPROPERLY USED OR OUT OF BALANCE STILTS ARE NOT ONLY UNCOMFORTABLE AND TIRING BUT COULD ALSO BE UNSAFE.

DURA-STILTS

Diagram

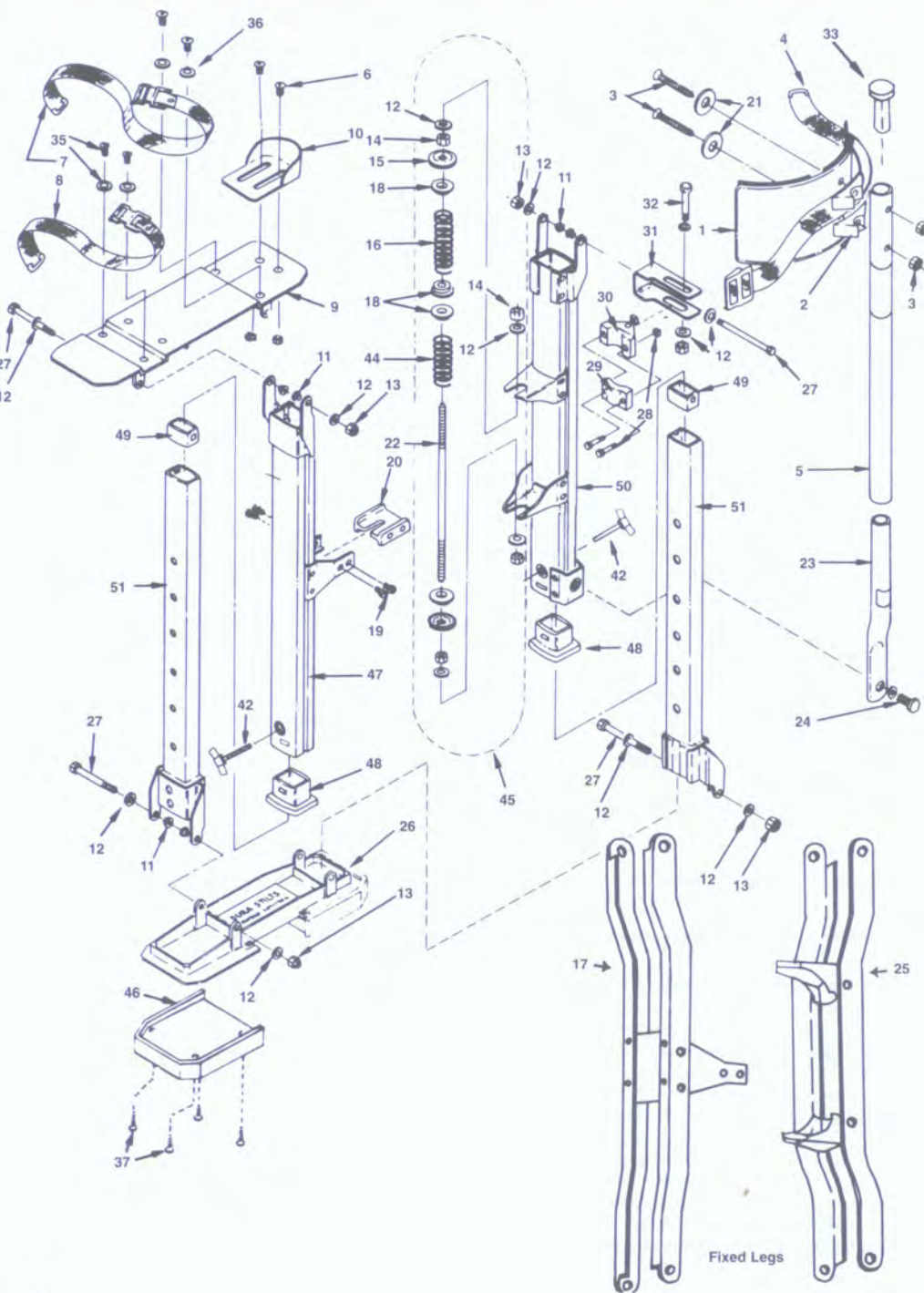

STEP D

WALKING

1 LEARNING TO WALK

IMPORTANT—Read the do's and don'ts for the use of Dura-Stilts (page 9) before you attempt to learn to walk on Dura-Stilts. Remember, in order to develop safe work habits, it is very important that you observe the do's and don'ts as you learn to walk on and use Dura-Stilts.

Select a clear and level area (preferably near a wall) but away from doors, floorvents, stairwells, windows, etc. With the help of a colleague, mount your Dura-Stilts and take slow deliberate short steps while keeping your stilts well apart. Make certain that each step completely clears the floor, as you must never drag or shuffle your feet. While assisted, walk slowly back and forth numerous times making a U turn to reverse your direction. Repeat walking back and forth until you develop a "feel" for the stilts. Practice walking until you feel secure and are able to walk unassisted.

2 ADJUSTMENT FOR WALK

If you have a tendency to lean forward or backward while walking on Dura-Stilts, you should adjust the action springs. Make the following adjustments with the help of a colleague, or after removing your stilts. To correct for leaning forward while walking, tighten the upper spring adjuster. To correct for leaning backward while walking, tighten the lower spring adjuster. It should not be necessary to tighten both upper and lower spring adjusters at the same time for any given individual. **Never tighten adjusters more than 1/5 of the way down, or approximately 15 turns (4 Full Revolutions) as it will limit the stilts action and impose excess stresses on the component.**

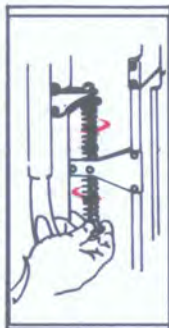

3 WALKING PRECAUTIONS

IMPORTANT—Always take short, deliberate, distinct steps and walk with your stilts well apart. Large or over-extended steps can cause the action springs to bottom out and place excess stresses on the the stilt components. Excess stresses could drastically reduce the life of the stilts or result in component breakage. If you walk on Dura-Stilts in such a way that the action springs are repeatedly compressed to solid, you are abusing them and using them beyond the scope of their intended purpose and load limit.

If your use for the Dura-Stilts requires stepping sideways, practice this movement with extreme caution. Look where your next step will be, raise your stilt well clear of the floor, then "plant" your stilt. Make certain that you practice this distinct movement until you can do it safely.

STEP E

WORKING

1 BEFORE YOU WORK

You should not attempt to perform work on Dura-Stilts until you have spent considerable time practicing, and becoming proficient on them. You should feel very comfortable, confident, and at ease while using them. **Do not work on Dura-Stilts until you have read and are willing to observe these instructions on the use of them, including the do's and don'ts.**

2 INSPECT BEFORE USE

Develop a habit of inspecting your Dura-Stilts before each days use. Make certain the entire stilts are free of any sign of damage or excessive wear, and that **all nuts and bolts are tight**. Special attention should be given to the entire strut tube assemblies and wing-bolts in this respect. Keep all labels legible.

3 HEIGHT ADJUSTMENT (D MODELS ONLY)

Remove wingbolts. Evenly raise the stilt legs to the desired height, align the wingbolt holes in the legs and extension tubes, install wingbolts, and **tighten well**.

4 TOP STOP FEATURE

Dura-Stilt legs and extension tubes are prevented from accidental separation at peak adjustment by the small sleeves stopping against the large sleeves. The sleeves may be **damaged or dislocated** if Dura-Stilts are adjusted into the peak range with harsh, rapid force. Damaged or dislocated sleeves can result in excessive "play" or "looseness" in the stilt legs and also leg and extension tube separation at peak adjustment. **Exercise care when adjusting your Dura-Stilts.**

STEP F MAINTENANCE

1 LUBRICATION

In order to keep your Dura-Stilts operating freely, it is necessary to keep the "action" components reasonably clean and free of dents or burrs. (Action components are those that pivot, slide, telescope, etc.) Lubricate the "action" components lightly with a silicone spray or white graphite powder. Do not use lubricating products which will remain wet and attract grit. Make certain soles are kept free of lubricants or any foreign matter which could cause loss of traction.

2 REPLACEMENT PARTS

All Dura-Stilt components are replaceable, or serviceable. Determine the stilt model and size (outlined below) then refer to the parts list on pages 5-6. Contact your dealer for parts needs.

WARNING: Do not make modifications or substitutions on parts or reassembly of Dura-Stilts. Always use genuine Dura-Stilt replacement parts. Never use parts from IMITATION brands.

MODELS/SIZES

"D" models are adjustable Dura-Stilts. Determine "D" model sizes by setting to lowest (shortest) height, and measuring the distance from the floor to the top of the footplate. Model D14-22 will measure about 14"; Model D18-30 will measure about 18" and Model D24-40 will measure about 24".

"F" models are fixed height or non-adjustable Dura-Stilts. Determine "F" model sizes by measuring from the floor to the top of the footplate. "F" models will measure 14", 16", 18", 20", 22", and 24".

3 REPLACEMENT OF NYLON SLEEVES

Remove wingbolts (#42) and set stilts to lowest position. Using screwdrivers, depress both plastic tabs in the leg slots (located just below the wingbolt holes). With tabs depressed, ease the large sleeve (#48) (together with the extension tubes and floor plate), out of the stilt legs as a unit. Cut or pry the small sleeves (#49) from the extension tube upper ends, and remove. The large sleeves can now be removed. (Note the orientation of the large sleeves for correct reassembly.)

To reassemble, check extension tube holes for burrs, file smooth if needed. Slide new large sleeves down over the extension tubes until the large sleeve tabs are aligned over the detents at the bottom of the extension tubes. Insert new small sleeves over the top of the extension tubes until it "snaps" past the upper locking tabs of the extension tubes. Carefully insert the extension tube units all the way into the stilt legs until the large sleeve tabs "snap and lock" into the stilt leg slots. Check stilt operation by adjusting stilts up and down. Replace wingbolts and **tighten well**.

4 QUESTIONS? NEED HELP?

If you have comments or questions concerning Dura-Stilts, please contact the North American MASTER DISTRIBUTOR on page 10. They will be glad to help you!

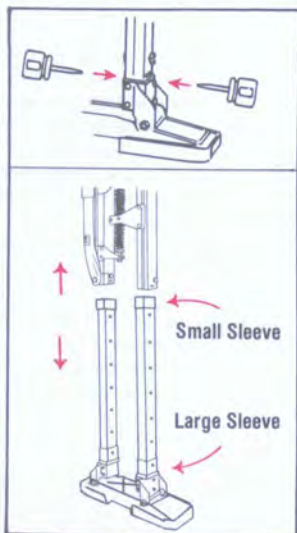

DO'S AND DON'TS

For the Use of DURA-STILTS®

DO'S

- Do...inspect stilts thoroughly before use, making sure that the structure is free of any sign of damage, that there is no excessive wear at the connection points, and that all bolts are tight. Special attention should be given to the entire strut tube assemblies and wingbolts in this respect.
- Do...replace any damaged or excessively worn stilt components before use.
- Do...assure the safety and quality of DURA-STILTS by using only genuine DURA-STILTS components.
- Do...fasten the upper leg strap first when putting on stilts.
- Do...remove anything from the soles which could cause loss of traction.
- Do...keep all straps tightly fastened and secured.
- Do...remove stilts to adjust them unless assisted by another person.
- Do...take short and distinct steps, making sure that the stilts are raised well clear of floor with each step. (Your stride may be lengthened as you become more confident.)
- Do...walk forward only, making a "U" turn to reverse your direction.
- Do...keep stilts adjusted properly.
- Do...always look where you're stepping.
- Do...walk only on suitable hard surface and level terrain.
- Do...cover or guard floor openings, stairwells, etc.
- Do...remove stilts when climbing or descending stairs.
- Do...receive assistance when retrieving objects from the floor.
- Do...be cautious when working around low profile furniture and fixtures, pipes, protrusions, etc.
- Do...disconnect upper leg straps last when removing stilts.

DON'TS

- Don't...wear stilts without having the proper instruction on the use of them.
- Don't...wear stilts that are uncomfortable or out of adjustment.
- Don't...wear stilts without having properly inspected them.
- Don't...wear stilts that have damaged, excessively worn or modified components.
- Don't...compromise DURA-STILTS quality by using components of IMITATION brands.
- Don't...walk on oily or otherwise slippery surfaces.
- Don't...walk on sandy, rocky, uneven, muddy, or excessively soft terrain.
- Don't...work around uncovered floor openings, stairwells, etc.
- Don't...work in or around loose wire, rope, electric cords, paper sacks, broken glass, conduit, etc.
- Don't...walk on secondary scaffolding, benches, planks, stairs, steps, stools, etc.
- Don't...carry heavy loads while walking on stilts.
- Don't...run or walk fast on stilts.
- Don't...pick up objects which are lower than foot level.
- Don't...wear stilts that are taller than necessary.
- Don't...become so overconfident that you fail to exercise caution.
- Don't...lean over desks, files, boxes or other objects while on stilts.
- Don't...be irresponsible on stilts.
- Don't...wear stilts while under the influence of drugs or alcohol.
- Don't...take steps so large that the action springs bottom out.
- Don't...modify this product in any manner.

CAUTION

Dura-Stilts are made of aluminum and therefore will conduct electricity. Exercise extreme caution when working around electrical sources as a shock could result.

DURA-STILT WARRANTY

Retain this Warranty for your records and enter warranty card number in box above.

Stilt Model/Size _____ Date Purchased _____ / _____ / _____

Dealer Where Purchased _____

All warranties contained herein are non-transferable and limited exclusively to original purchasers of the Dura-Stilts. The literature statements, technical information, and recommendations are based on information we believe to be true and reliable, but the accuracy or completeness thereof is not guaranteed.

90 DAY LIMITED WARRANTY

IAM of Puerto Rico Inc. warrants the Dura-Stilts to be free of defects in material and workmanship for a period of 90 days following the date of purchase, provided the Dura-Stilts are properly assembled, used and maintained in accordance with the Dura-Stilt instructions included with the product. Excluded from this warranty are Dura-Stilts subjected to abuse, misuse, neglect, modification, and accidental or intentional damage.

ONE YEAR LIMITED STRUCTURAL WARRANTY

IAM of Puerto Rico Inc. warrants all Dura-Stilt structural components to be free of defects in material and workmanship for a period of one year following the date of purchase, provided the Dura-Stilt is properly assembled, operated and maintained in accordance with the Dura-Stilt instructions included with the product. Excluded from this warranty are components subject to normal wear including but not limited to, nylon bearings, sleeves, leg band pads, soles, springs, and straps. Also excluded from this warranty are Dura-Stilt components subjected to abuse, misuse, neglect, modification and accidental or intentional damage.

WARRANTY SERVICE

For warranty service return the Dura-Stilts or component, with explanation prepaid to the MASTER DISTRIBUTOR indicated below. They will repair or replace the component in question and return the product to you free of charge.

MASTER DISTRIBUTOR

DURA-STILT SALES LIMITED PARTNERSHIP

A NEVADA LIMITED PARTNERSHIP

P.O. BOX 271313 OKLAHOMA CITY, OK 73137-1313

8316 S.W. 8TH OKLAHOMA CITY, OK 73128

1-800-225-2440

405/495-2440

All warranties contained herein are limited only to repair and replacement of parts and product. Excluded from all warranties contained herein are inbound freight and postage, freight losses, labor charges outside our facility and damages caused by the customer improperly assembling the Dura-Stilts, or any accidental or intentional damage. Also excluded from all warranties contained herein are consequential damages, incidental damages and damages to persons and/or property connected with the use of Dura-Stilts.

IAM of Puerto Rico reserves the right to change, modify or improve the design of Dura-Stilts without assuming any obligations or liabilities relating to any Dura-Stilt previously manufactured by IAM of Puerto Rico Inc. or any other source.

BINDING ARBITRATION

USE OF THIS PRODUCT SIGNIFIES YOUR WILLINGNESS TO AGREE TO THE FOLLOWING BINDING ARBITRATION CONTRACT.

In consideration of the timely and cost effect resolution of controversies between the parties, all such controversies regarding the Agreement or the rights of parties hereto, shall be submitted to arbitration before the American Arbitration Association. The parties agree to waive their rights to a jury trial, punitive damages, tort damages, attorneys fees, cost, or expenses as a result of this Agreement or enforcement of the arbitration's award, the parties agree that venue lies in Oklahoma County, State of Oklahoma, and the parties waive their right to a jury trial for any claims or counter claims. This arbitration clause shall survive the termination of breach of the agreement. If any provision of the Arbitration Clause is held invalid, that invalidity shall not affect other provisions of this Arbitration Clause.

If you are unwilling to agree to and abide by this BINDING ARBITRATION AGREEMENT YOU MUST NOT USE THIS PRODUCT.

IMPORTANT SAFEGUARDS

Read and follow all instructions concerning your new Dura-Stilts.

Strictly follow all instructions labels on this product.

Save the instructions for later use.

Remember: Proper inspection, maintenance and treatment of this product is crucial to your product satisfaction and personal safety.

DO NOT MODIFY THIS PRODUCT

Always use genuine Dura-Stilts replacement parts.